



GRANT DETECTION

ANSELMA®-INDUSTRIE

Handheld Heartbeat Detector MMD01



**New technology of heartbeat detection
of humans hidden in vehicles.**



GRANT DETECTION

ANSELMA®-INDUSTRIE

Handheld Heartbeat Detector MMD01

New technology of heartbeat detection of humans hidden in vehicles



- Innovative and patented technology of heartbeat detection of persons and animals hidden in vehicles
- Used by border forces, police, prison services, military police, customs administration and high security facilities
- Inspects cars, vans, trucks, buses, containers placed on the vehicles
- Simple operation by one person
- Measuring process within 30 seconds
- Fully mobile, can be a part of any checkpoint or car patrol
- Can be used 24/7, powered either by standard 230V or 12 V car socket
- No negative impact on human health or environment
- CE-Certificate, produced in EU



EVROPSKÁ UNIE
Evropské strukturální a investiční fondy
OP Praha – pól růstu ČR



Used by EU Border Forces



GRANT DETECTION

ANSELMA®-INDUSTRIE

ONE BUTTON – ONE RESULT WITHIN 30 SECONDS!

HANDHELD HEARTBEAT DETECTOR MMD01

New technology of heartbeat detection of humans hidden in vehicles



TECHNICAL SPECIFICATION

| Parameter | Unit | Value |
|--------------------------------|---------|------------------------|
| Device dimensions | cm | 14 X 22.5 X 5 |
| Portable container dimensions | cm | 27 X 25 X 12,4 |
| Device weight | kg | 1.3 |
| Weight with portable container | kg | 2.5 |
| Diagonal of the display | inches | 3 |
| Meantime per measurement | s | 20 |
| Input voltage | V | 230 |
| Operational temperature range | °C | -20 to 50 |
| Rechargeable battery life | hours | 8 to 12 |
| Charger plug | CEE7/16 | 12V car socket |
| IP Protection | – | min. IP33 |
| Operating language | | English/German/Spanish |

Delivery includes:

Detector MMD01 • Transport Case • Adapter for 230V socket
Adapter for 12V car socket • Instruction Manual

Save time and money with our MMD01 handheld detector.



GRANT DETECTION

ANSELMA®-INDUSTRIE

Handheld Heartbeat Detector MMD01

Detection methodology

All doors must be closed, the engine and other vehicle equipment must be switched off, all persons must exit the vehicle and the vehicle tarpaulin must be secured. The detector shall always be placed on the vehicle structure, as close to the vehicle axle as possible, ideally above or close to the axle wheel. If the vehicle has more than one axle in one place, it is advisable to carry out the detection between the wheels of these axles. Performing fewer detections than recommended for each vehicle type may reduce the reliability of the detection. If the vehicle is equipped with a thicker insulation layer (e.g., polystyrene), the detection reliability may be reduced. Only after the detections made at all recommended locations for each vehicle are negative can it be stated with greater than 95% confidence that no one is hiding in the vehicle.

Trucks (tractors) with semi-trailers, including tankers, open-bodied semi-trailers and semi-trailers carrying passenger vehicles



Place the detector on the chassis structure of the tractor and trailer, see picture, not on the body of the tractor or container. If the tanker is carrying a liquid load, the vehicle must be left stationary for at least 5 minutes before detection.

Trucks with trailer



Place the detector on the chassis structure of the vehicle and trailer, see illustration, not on their bodywork or the container on top of them.

Small trucks



Place the detector on the chassis structure of the vehicle, see picture, not on the body of the vehicle or the container on top of it.

Vans and passenger vehicles



Place the detector on the bodywork above the rear wheel, see picture, ideally on the side of the vehicle where there is no sliding door.

Buses



Place the detector on the vehicle chassis structure, see picture, not on the vehicle body or outer shell. If the vehicle structure does not allow such detection (e.g. due to lack of access to the chassis), open the bus storage compartments and place the detector on the internal structure of the bus, both at the front and at the rear of the bus, ideally in a cross (right at the front and left at the rear or vice versa).

Refrigerator trucks



Place the detector on the vehicle chassis structure, see picture, not on the vehicle body. It is desirable that the cooling is switched off during detection. If the vehicle's cooling cannot be switched off, detection may be performed, but the reliability of detection may be reduced.

Special vehicles

Place the detector on the vehicle chassis structure, not on the vehicle body or outer shell. Detection must be made above or near all axles of the vehicle. If the vehicle structure does not allow such detection (e.g., due to lack of access to the chassis), open the vehicle's storage compartments and place the detector on the vehicle's internal structure, both at the front and rear of the vehicle, ideally in a cross pattern (right front and left rear or vice versa). If access to the luggage compartment is not possible, place the detector on other supporting elements of the vehicle, as close as possible to the axles of the vehicle, but always firmly connected to the vehicle structure.



Handheld Heartbeat Detector MMD01

1. Features overview

- The MMD01 handheld detector is a portable detector of living organisms (humans and animals) in vehicles.
- The MMD01 handheld detector is mainly intended for national (army, police, customs administration, prison service) and private security forces and logistics companies.
- The MMD01 handheld detector is created to inspect cars and trucks, including containers placed on the vehicles.
- The MMD01 handheld detector uses the principle of heartbeat detection.
- The MMD01 handheld detector can be operated by one person.
- The MMD01 handheld detector is easy to operate and measures quickly (within 30 seconds).
- The MMD01 handheld detector is mobile and can therefore be part of the equipment of any checkpoint or car patrol.
- The MMD01 handheld detector can be used 24/7, as it can be powered by either a standard 230 V outlet or a car socket.
- The MMD01 handheld detector has no negative impact on the environment when in use and does not affect human health.

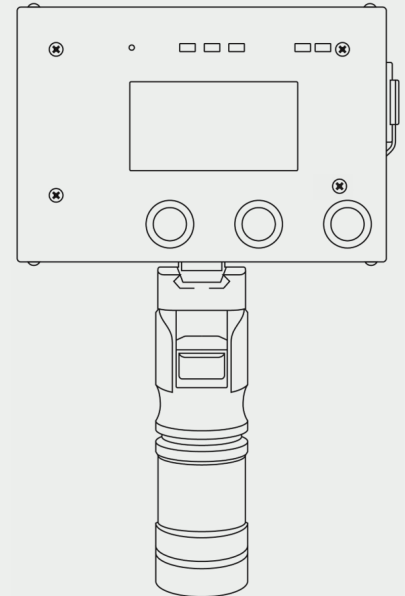

2. Description of the MMD01 handheld detector

The MMD01 handheld detector is appropriate for use by national security forces (customs administration, army, police, prison service), as well as private security agencies and logistics companies that need to prevent the illegal movement of people and animals, especially in international transportation.

The MMD01 handheld detector uses the principle of detecting low mechanical vibrations caused by hemodynamics, without using potentially harmful electromagnetic radiation. The MMD01 handheld detector functions reliably on vehicles where this mechanical vibration is transmitted to the structure. In exceptional cases, such transmission may not occur sufficiently in vehicles of special construction.

The MMD01 handheld detector can be used to verify the presence of people or animals hidden in vehicles without the need to physically open the vehicle. The MMD01 handheld detector uses one internal sensor and contains no other external components. In case of heartbeat activity detected from the checked vehicle, pictogram is shown on the display of the device. The device is attached to the vehicle using magnetic system. The device uses advanced algorithms to filter disruptive meteorological and environmental conditions (software filtering and metering averaging). The internal sensor signal, obtained before and during the measurement, is used to filter out interference so that there is no need to connect an environmental sensor.

3. Technical specifications

| Parameter | Unit | Value | Parameter | Unit | Value |
|--------------------------------|--------|----------------|-------------------------------|---------|------------------------|
| Device dimensions | cm | 14 X 22.5 X 5 | Input voltage | V | 230 |
| Portable container dimensions | cm | 27 X 25 X 12,4 | Operational temperature range | °C | -20 to 50 |
| Device weight | kg | 1.3 | Rechargeable battery life | hours | 8 to 12 |
| Weight with portable container | kg | 2.5 | Charger plug | CEE7/16 | 12V car socket |
| Diagonal of the display | inches | 3 | IP Protection | - | min. IP33 |
| Meantime per measurement | s | 20 | Operating language | | English/German/Spanish |